

电机数据	42STH33-0956A	42STH33-1334A	42STH38-1206A	42STH38-1684A	42STH47-1206A	42STH47-1684A	
1 电机编号	42STH33-0956A	42STH33-1334A	42STH38-1206A	42STH38-1684A	42STH47-1206A	42STH47-1684A	
2 1 相电压	4	2.8	4	2.8	4	2.8	V
3 2 相电流	0.95	1.33	1.2	1.68	1.2	1.68	A
4 3 相电阻	4.2	2.1	3.3	1.65	3.3	1.65	Ω
5 4 相电感	2.5	2.5	3.2	3.2	2.8	2.8	mH
6 5 静力矩	16.0	22.0	26.0	36	31.7	44	N.cm
7 6 引出线数	6	4	6	4	6	4	
8 7 转动惯量	35.0	35.0	54.0	54	68	68	gcm ²
9 8 长度	33	33	38	38	47	47	mm
10 9 质量	0.22	0.22	0.28	0.28	0.35	0.35	kg
通用规格							
11 10 步距角	1.8°						
12 11 步距角精度	±5% (整步、空载)						
13 12 电阻精度	±10%						
14 13 电感精度	±20%						
15 14 绝缘电阻	500VDC 100MΩMin						
16 15 绝缘强度	500VAC 1 minute						
17 16 环境温度	-20℃-- +50℃						
18 17 温升	80℃ Max(额定电流)						
19 18 轴向跳动	0.08mm Max(450g 负载)						
20 19 径向跳动	0.02mm Max(450g 负载)						
21 20 轴向最大力	10N						
22 21 径向最大力	28N(20mm 边缘为标准)						
23 22 绝缘等级	B						

尺寸图

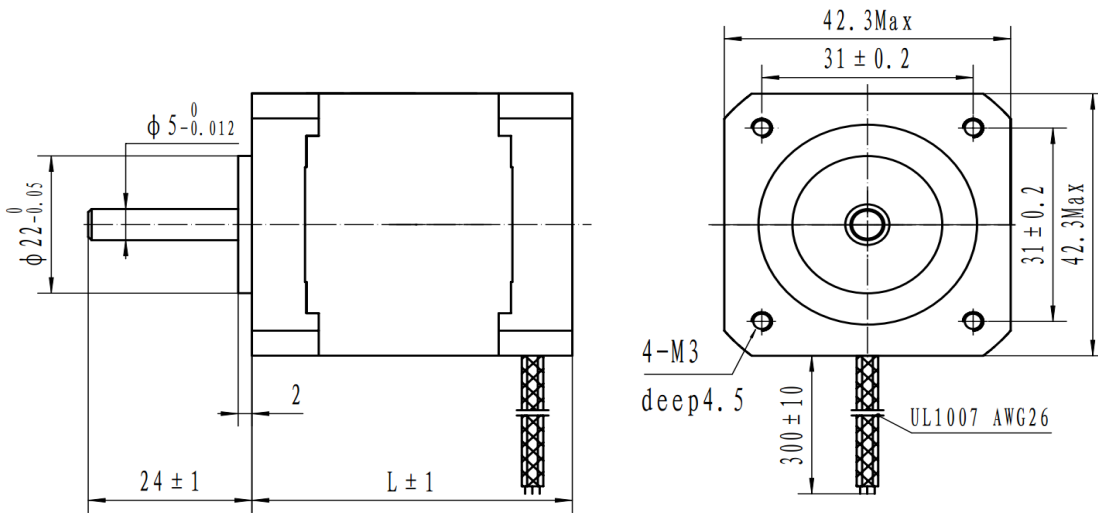

选件, 电缆和连接信息

Connection Motor (UL1007 AWG26)

